



WALL TWISTER PVP 110 GAS

SERIES: PAVESI ROTATING OVENS

JOB NAME: _____

REFERENCE INVOICE #: _____



Standard Pavesi Wall Twister 110 Gas

CUSTOM FACADE: YES NO

CUSTOM FACADE DOCUMENT #: _____

BURNER POSITION: L R

EXTENDED OVEN OPENING: 32"

• Pavesi Wall Twister 110 Gas is constructed in a place by a certified Forza Forni Technician.

REFRACTORY MONOBLOCK FLOOR

The Pavesi Wall Twister features the world's only refractory commercial brick oven floor in one solid block.

VERSATILE & RELIABLE

The Pavesi Wall Twister design exceeds at holding a wide variety of temperatures to achieve almost any pizza size and style.

TRADITION & TECHNOLOGY

The Pavesi Wall Twister is designed to preserve traditional Italian hearth oven dynamics with the ease and consistency of a rotating floor.



Approved by the Association of Neapolitan Pizzaiuoli of America

FEATURES

The Pavesi Wall Twister 110 Gas is a hand-built Italian hearth-style brick oven which features a rotating refractory oven floor. The solid, single piece refractory floor diameter is 43 1/4", with a front-facing oven arch opening which allows access to the hearth at 23" wide by 11" tall. The gas burner is a dual-flame Venturi-type burner that can be used with either Natural gas or LP gas. The primary flame heats the oven hearth up to 1000° F. A foot-pedal activates the second burner for a burst of energy to provide top heat for pizza baking. The internal refractory dome and single piece floor are sealed with a refractory cement and over-insulated with high quality asbestos-free ceramic blankets to ensure maximum heat retention. The oven structure is formed by a steel box structure painted "Rosso Corso" red, and sits on top of four circular dark grey steel legs. Custom facade options can be found online at www.forzaforni.com.

BAKING SURFACE	OVEN OPENING	EXTERNAL WIDTH	EXTERNAL DEPTH

GAS REQUIREMENTS

This equipment may be used with LP gas or natural gas.

CONNECTION SIZE:	0.5" Male threaded			
	LP GAS		NATURAL GAS	
GAS PRESSURE:	11-13 in H ₂ O		3.5 in H ₂ O	
ORIFICE SIZE:	● #40	○ #40	● #22	○ #30
HOURLY BTU INPUT RATING:	80,000 Btu/Hr	150,000 Btu/Hr	45,000 Btu/Hr	110,000 Btu/Hr

● PRIMARY BURNER ○ BOOSTER BURNER (Booster burner controlled by foot pedal to provide top heat at desired moment)

OVEN PRODUCTION

	12"	16"
PIZZA CAPACITY	8-10 PIZZAS	4 PIZZAS
RECOMMENDED BAKING TIME:	1.5-3 MINUTES	3-5 MINUTES
OVEN TEMP RANGE:	600-900 °F	500-700 °F
DAILY PREHEAT TIME:	45 MINUTES	

ROTATION MOTOR CONTROL PANEL



FORZA FORNI
601 N Main St, Brewster, NY 10509
Email: info@forzaforni.com
www.forzaforni.com

844-OVEN-INC (844-683-6462)
Toll-free in USA
(Hablamos Español,
Falamos Português)

Listed to: UL 2162-ULC/ORD C2162,
ANSI Z83.11-CSA 1.8, & NSF-4 for
Commercial Wood Fired and
Gas Fired Cooking Equipment



DOC#: WALLTW110-0420-1

REVISED SPRING 2017. As products continue to improve, spec sheets may change without notice. Please call Forza Forni for the latest specification sheet and for further details.

MADE IN ITALY



WALL TWISTER PVP 110 GAS

SERIES: PAVESI ROTATING OVENS

DETAILED SPECS

WEIGHT:
2,860 LB

We make every effort to provide accurate information regarding manufacturer's reported dimension information. Please note that due to the artisan nature of the manufacturing process, from time to time, product sizing and ship weight may vary slightly.

FRONT ELEVATION

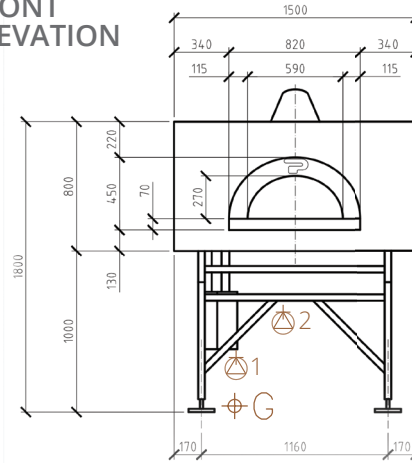

OVERHEAD VIEW

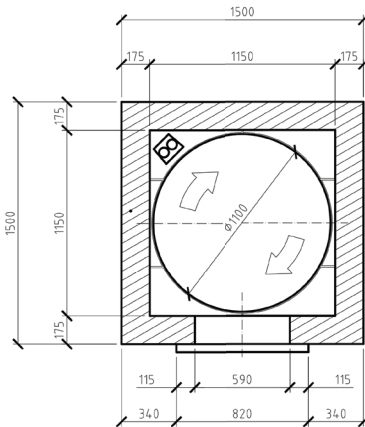

LEFT ELEVATION

Pictured:
Left Gas Disposition

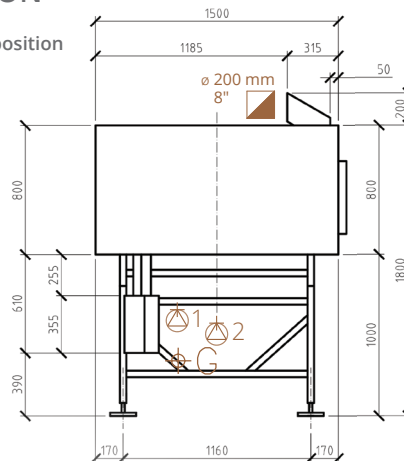

KEY

	Gas Burner Electrical Connection
	Rotation Motor Electrical Connection
	Gas Connection
	Flue Collar Exhaust Connection
	Gas Burner

All measurements listed in millimeters

CLEARANCES

Minimum clearance of the oven (built-in or standalone) to combustible materials are as follows:

Top: 14" (356 mm)
Back & Sides: 1" (25 mm)

- Non-combustible flooring must extend out at least 36" (914 mm) from oven opening and at least 30" (762 mm) to each side of the opening.
- Do not fill required air space with insulation or other materials.

VENTILATION REQUIREMENTS

Direct connection as a natural draft, grease-rated chimney system per NFPA 96 and UL 2162 is recommended. If the duct run exceeds 20 feet or incorporates a 90° elbow, a UL 705 & UL 762 listed rooftop exhaust fan shall be installed to ensure adequate pressure within the duct. A Listed Type 1 exhaust hood, or one constructed in accordance with

all relevant local and national codes (NFPA 96), may also be installed above the oven in instances where a natural/power draft chimney system is otherwise impossible. See "Ventilation Document - Pavesi" for details.

Operational airflow: 150-200 CFM
Static Pressure at Flue Collar: 0.05 in H₂O

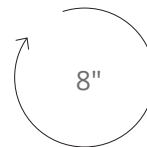

FLUE COLLAR CONNECTION DIAMETER (EXTERNAL)

ELECTRICAL REQUIREMENTS

- | | |
|----------------------------|--------------------------|
| Gas Burner | Rotation Motor |
| ■ 120 VAC,
0.5 A, 60 Hz | ■ 120 VAC,
7 A, 60 Hz |

WARRANTY INFORMATION

10 year limited warranty on internal refractory parts, 1 year limited warranty on electrical, gas and other components. See warranty document for details.

FORZA FORNI
601 N Main St, Brewster, NY 10509
Email: info@forzaforni.com
www.forzaforni.com

844-OVEN-INC (844-683-6462)
Toll-free in USA
(Hablamos Español,
Falamos Português)

Listed to: UL 2162-ULC/ORD C2162,
ANSI Z83.11-CSA 1.8, & NSF-4 for
Commercial Wood Fired and
Gas Fired Cooking Equipment

