



# WALL TWISTER PVP 150 GAS

SERIES: PAVESI ROTATING OVENS



Standard Pavesi  
Twister PVP 150 Gas

JOB NAME: \_\_\_\_\_

REFERENCE INVOICE #: \_\_\_\_\_

CUSTOM FACADE:  YES  NO

CUSTOM FACADE DOCUMENT #: \_\_\_\_\_

BURNER POSITION:  L  R

• PVP Wall Twister 150 Gas is constructed in a place by a certified Forza Forni Technician.

## REFRACTORY MONOBLOCK FLOOR

The Pavesi PVP Wall Twister features the world's only refractory commercial brick oven floor in one solid block.

## VERSATILE & RELIABLE

The Pavesi PVP Twister design exceeds at holding a wide variety of temperatures to achieve almost any pizza size and style.

## TRADITION & TECHNOLOGY

The Pavesi PVP Wall Twister is designed to preserve traditional Italian hearth oven dynamics with the ease and consistency of a rotating floor.



Approved by  
the Association  
of Neapolitan  
Pizzaiuoli of  
America

## FEATURES

The Pavesi PVP Twister 150 Gas is a hand-built Italian hearth-style brick oven which features a rotating refractory oven floor. The solid, single piece refractory floor diameter is 59", with a front-facing oven arch opening which allows access to the hearth at 23" wide by 11" tall.

A powerful twin flame gas burner sits opposite the wood fired oven grate to preserve the wood fired ambiance. The internal refractory dome and single piece floor are sealed with a refractory cement and over-insulated with high quality asbestos-free ceramic blankets to ensure maximum heat retention. The external structure is formed by a steel sheet wrap painted "Rosso Corso" red, and sits on top of four circular dark-gray powder-coated steel legs. Custom facade options can be found online at [www.forzaforni.com](http://www.forzaforni.com).

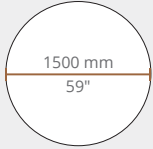
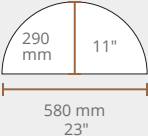
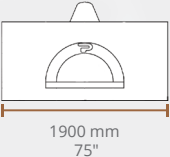
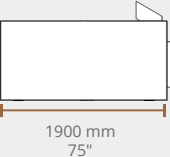
BAKING SURFACE	OVEN OPENING	EXTERNAL WIDTH	EXTERNAL DEPTH
			

## GAS REQUIREMENTS

This equipment may be used with LP gas or natural gas.

CONNECTION SIZE:	0.5" Male threaded			
	LP GAS	NATURAL GAS		
GAS PRESSURE:	11-13 in H <sub>2</sub> O	3.5 in H <sub>2</sub> O		
ORIFICE SIZE:	●	○	●	○
	#40	#40	#22	#30
HOURLY BTU INPUT RATING:	80,000 Btu/Hr	150,000 Btu/Hr	45,000 Btu/Hr	110,000 Btu/Hr

● PRIMARY BURNER ○ BOOSTER BURNER (Booster burner controlled by foot pedal to provide top heat at desired moment)

## OVEN PRODUCTION

12" PIZZA CAPACITY: 14 - 16 PIZZAS

RECOMMENDED BAKING TIME: 90 - 240 SECONDS  
(DEPENDING ON PIZZA STYLE)

RECOMMENDED OVEN FLOOR

TEMPERATURE RANGE: 600°F - 900°F  
(DEPENDING ON PIZZA STYLE)

DAILY PREHEAT TIME: 60 MINUTES

## ROTATION MOTOR CONTROL PANEL



FORZA FORNI  
601 N Main St, Brewster, NY 10509  
Email: [info@forzaforni.com](mailto:info@forzaforni.com)  
[www.forzaforni.com](http://www.forzaforni.com)

844-OVEN-INC (844-683-6462)  
Toll-free in USA  
(Hablamos Español,  
Falamos Português)

Listed to: UL 2162-ULC/ORD C2162,  
ANSI Z83.11-CSA 1.8, & NSF-4 for  
Commercial Wood Fired and  
Gas Fired Cooking Equipment



DOC#: PVPTW130G-0421-1

REVISED SPRING 2017. As products continue to improve, spec sheets may change without notice. Please call Forza Forni for the latest specification sheet and for further details.

MADE IN ITALY



# WALL TWISTER PVP 150 GAS

SERIES: PAVESI ROTATING OVENS

## DETAILED SPECS

**WEIGHT:**  
**3,080 LB**

We make every effort to provide accurate information regarding manufacturer's reported dimension information. Please note that due to the artisan nature of the manufacturing process, from time to time, product sizing and ship weight may vary slightly.

ALL DISPLAYED MEASUREMENTS ARE IN MILLIMETER UNITS

### FRONT ELEVATION

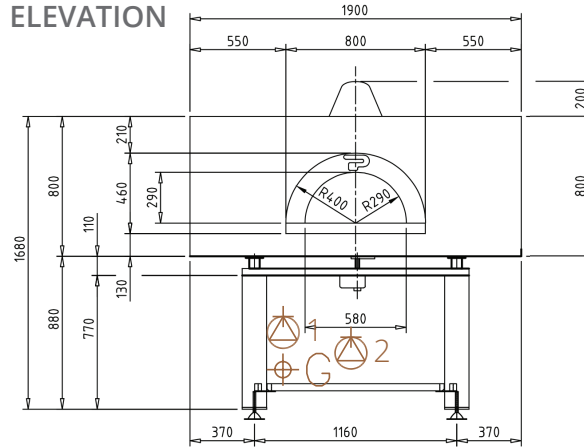

### PLAN VIEW

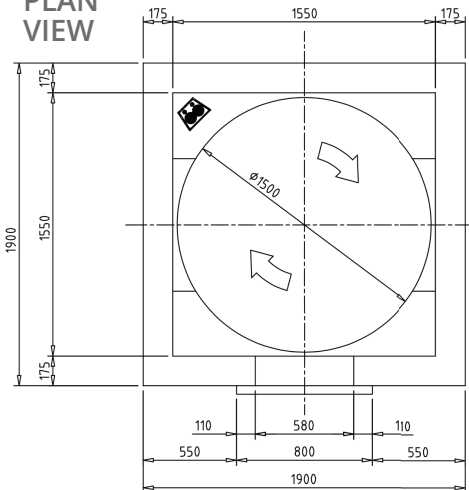

### LEFT ELEVATION

Pictured: Left Gas Disposition

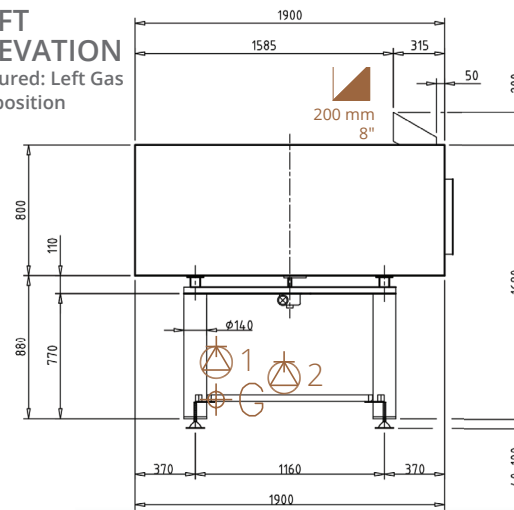

## KEY

	Gas Burner Electrical Connection
	Rotation Motor Electrical Connection
	Gas Connection
	Flue Collar Exhaust Connection
	Gas Burner

## CLEARANCES

Minimum clearance of the oven (built-in or standalone) to combustible materials are as follows:

**Top: 14" (356 mm)**  
**Back & Sides: 1" (25 mm)**

- Non-combustible flooring must extend out at least 36" (914 mm) from oven opening and at least 30" (762 mm) to each side of the opening.
- Do not fill required air space with insulation or other materials.

## VENTILATION REQUIREMENTS

Direct connection as a natural draft, grease-rated chimney system per NFPA 96 and UL 2162 is recommended. If the duct run exceeds 20 feet or incorporates a 90° elbow, a UL 705 & UL 762 listed rooftop exhaust fan shall be installed to ensure adequate pressure within the duct. A Listed Type 1 exhaust hood, or one constructed in accordance with

all relevant local and national codes (NFPA 96), may also be installed above the oven in instances where a natural/power draft chimney system is otherwise impossible. See "Ventilation Document - Pavesi" for details.

**Operational airflow:** 150-200 CFM  
**Static Pressure at Flue Collar:** 0.05 in H<sub>2</sub>O

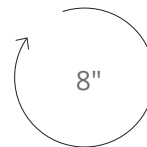

FLUE COLLAR CONNECTION DIAMETER (EXTERNAL)

## ELECTRICAL REQUIREMENTS

- |                         |                       |
|-------------------------|-----------------------|
| <b>Gas Burner</b>       | <b>Rotation Motor</b> |
| ■ 120 VAC, 0.5 A, 60 Hz | ■ 120 VAC, 7 A, 60 Hz |

## WARRANTY INFORMATION

10 year limited warranty on internal refractory parts, 1 year limited warranty on electrical, gas and other components. See warranty document for details.

**FORZA FORNI**  
601 N Main St, Brewster, NY 10509  
Email: [info@forzaforni.com](mailto:info@forzaforni.com)  
[www.forzaforni.com](http://www.forzaforni.com)

**844-OVEN-INC (844-683-6462)**  
Toll-free in USA  
(Hablamos Español, Falamos Português)

Listed to: UL 2162-ULC/ORD C2162, ANSI Z83.11-CSA 1.8, & NSF-4 for Commercial Wood Fired and Gas Fired Cooking Equipment

